

V 2.3

# MINI SY-04 Syringe Pump Manual

南京润泽流体控制设备有限公司  
NANJING RUNZE FLUID CONTROL EQUIPMENT CO.,LTD

# Table of Content

<b>Chapter 1 Product Introduction.....</b>	<b>3</b>
1.1 Overview.....	3
1.2 Naming Rules.....	4
1.3 Product Structure.....	4
1.4 Physical Dimension.....	5
1.4.1 MiNi SY-04 Syringe Pump without Driver.....	5
1.4.2 MiNi SY-04 Syringe Pump with Driver.....	7
1.5 42 Stepper Motor Introduction.....	7
1.6 Typical Application (Solenoid Valve Connected to Syringe Pump).....	8
1.7 Basic Parameters.....	9
1.8 Port Definition.....	11
<b>Chapter 2 Syringe Pump Control Code Instruction.....</b>	<b>12</b>
2.1 Overview.....	12
2.2 Installation and Debugging.....	12
2.3 Command Format Instruction.....	12
2.3.1 Control Command Format.....	12
2.3.2 Common Command Format (send 8 bytes, receive 8 bytes).....	12
2.3.3 Factory Command Format (send 14 bytes, receive 8 bytes).....	15
<b>Chapter 3 Common Problems And Solutions.....</b>	<b>19</b>
<b>Chapter 4 Technical Service.....</b>	<b>21</b>

# Chapter 1 Product introduction

## 1.1 Overview

The appearance of the MiNi SY-04 syringe pump is shown as below, it is designed with 5ml, 10ml, 20ml three specifications, according to whether there is a driver or not, they are divided into driver series and no driver series.



Application : MiNi SY-04 syringe pumps are widely used in biological, environmental and medical analyzers, it mainly used in biological analyzers, the controller and execution unit are split structure, the execution unit has clamping mechanism. It can be used with micromanipulators, stereoscopic brain locators and other biological instruments because of its exclusive structures of compact, small and exquisite, precise dispensing and easy installation.

## 1.2 Naming Rules

Model Parameters are shown as below

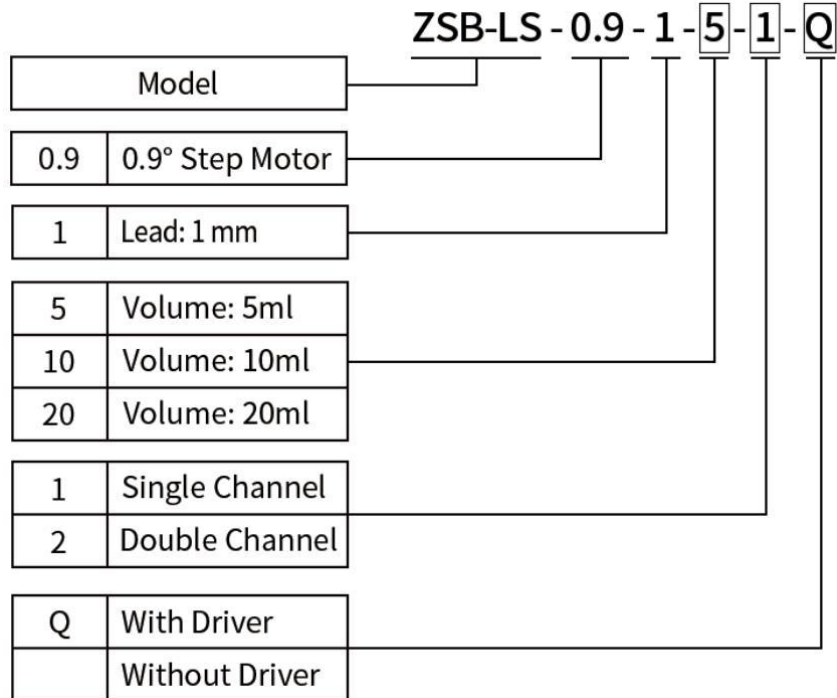

**E.g.:** ZSB-LS-0.9-1-5-1-Q refers to MiNi SY-04 syringe pump 5ml, step motor 0.9°, lead screw 1mm, single channel, with drive.

## 1.3 Product Structure

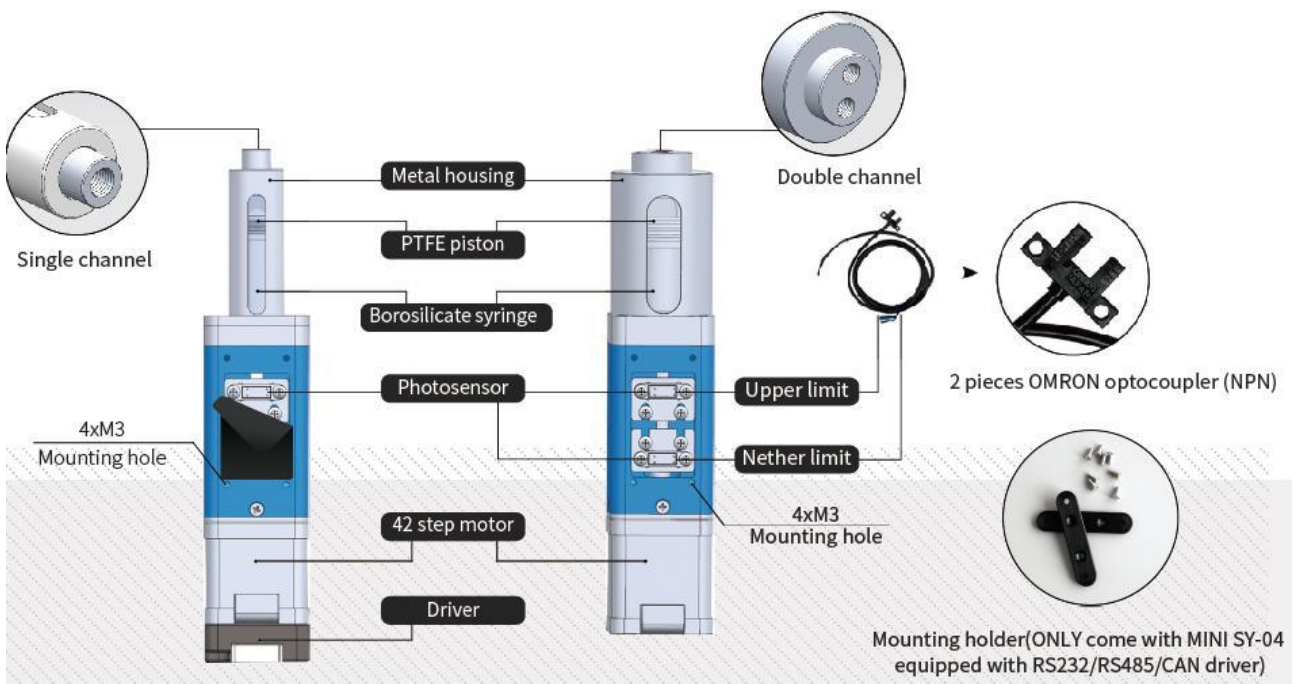

## 1.4 Physical Dimension

### 1.4.1 MiNi SY-04 Syringe Pump without Driver

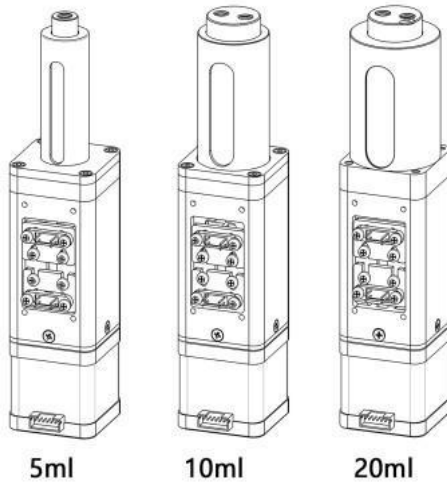

**OMRON photosensors**

MiNi SY-04 syringe pump without driver was designed with 2 pieces OMRON photosensors (Model No.: EE-SX95-R) to limit the upper and nether position which protect the cylinder and pump head from getting broken.

#### **OMRON photosensors adjustment method:**

Power on the pump until plunger reaching the upper position, then move the Optical coupling until it detected the signal, finally fixed the screw. The nether photosensors will be fixed at the lowest position.

Note: Low speed should be used during commissioning to prevent the piston from being squeezed to the upper end.



**1.4.1.1 Dimension (Unit : mm)**

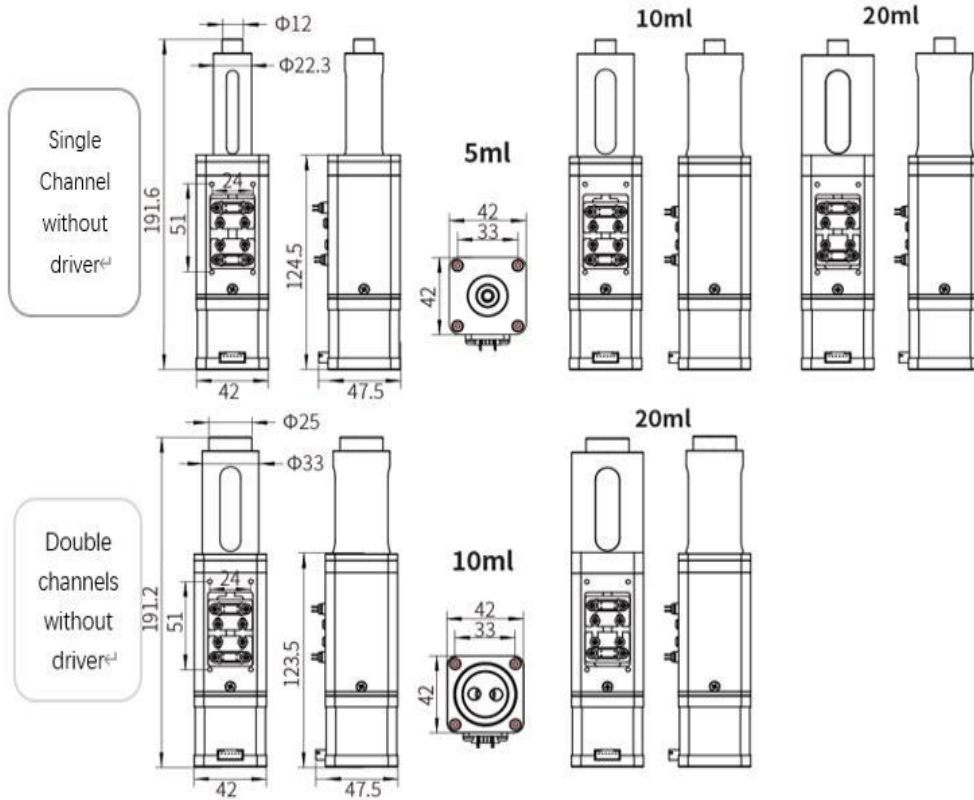

**1.4.1.2 Photoelectric sensors**

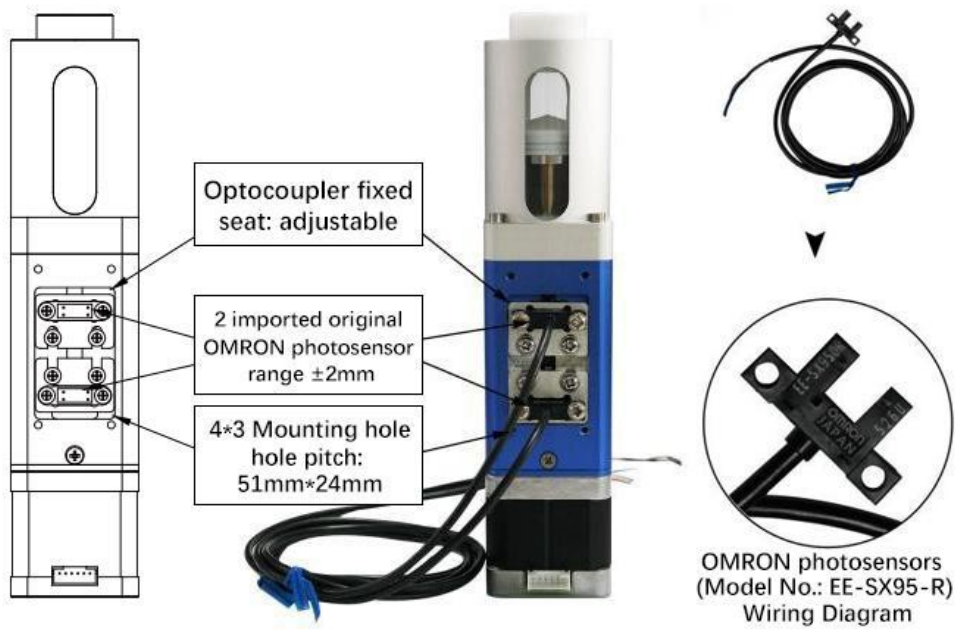

## 1.4.2 MiNi SY-04 Syringe Pump with Driver

### 1.4.2.1 MiNi SY-04 with Driver Dimension (Unit: mm)

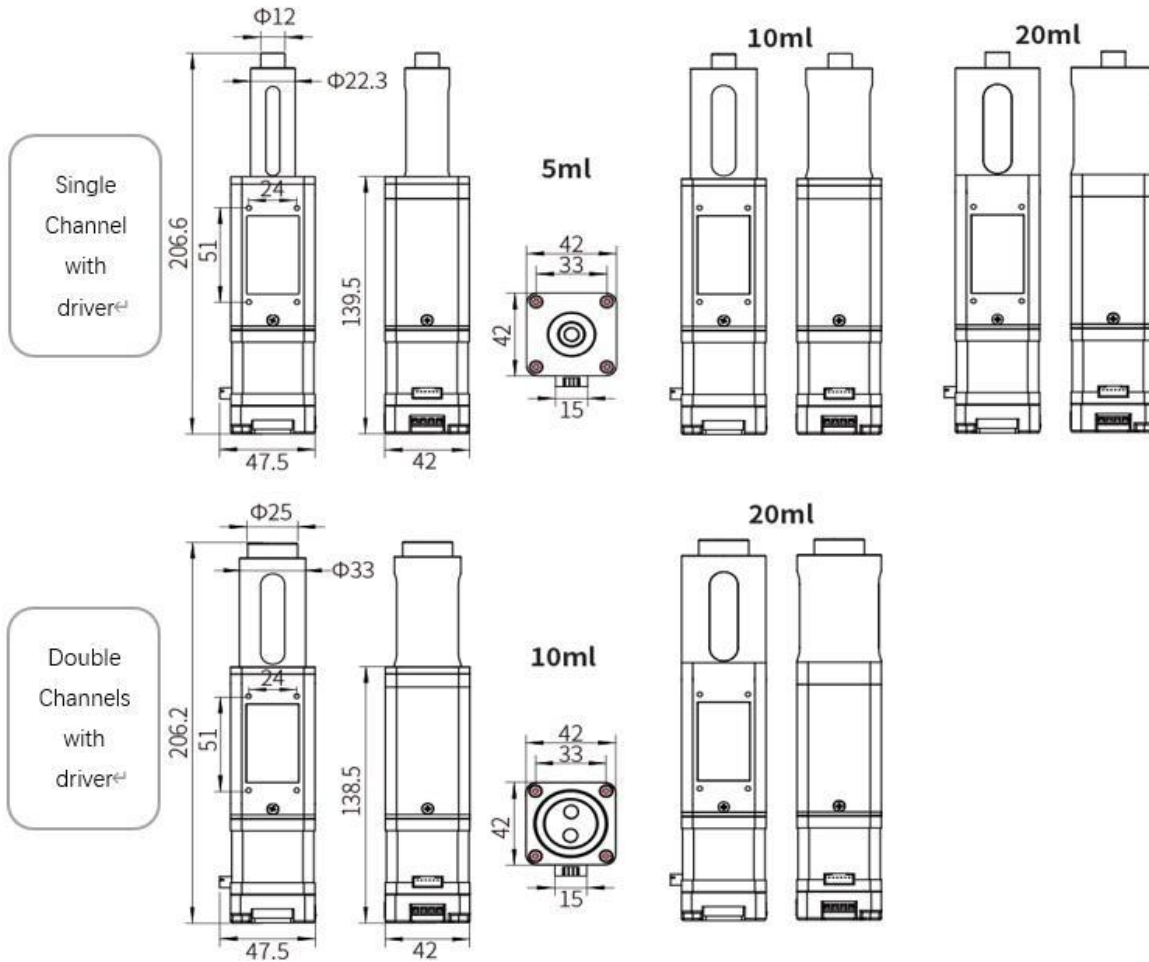

## 1.5 42 Stepper Motor Introduction

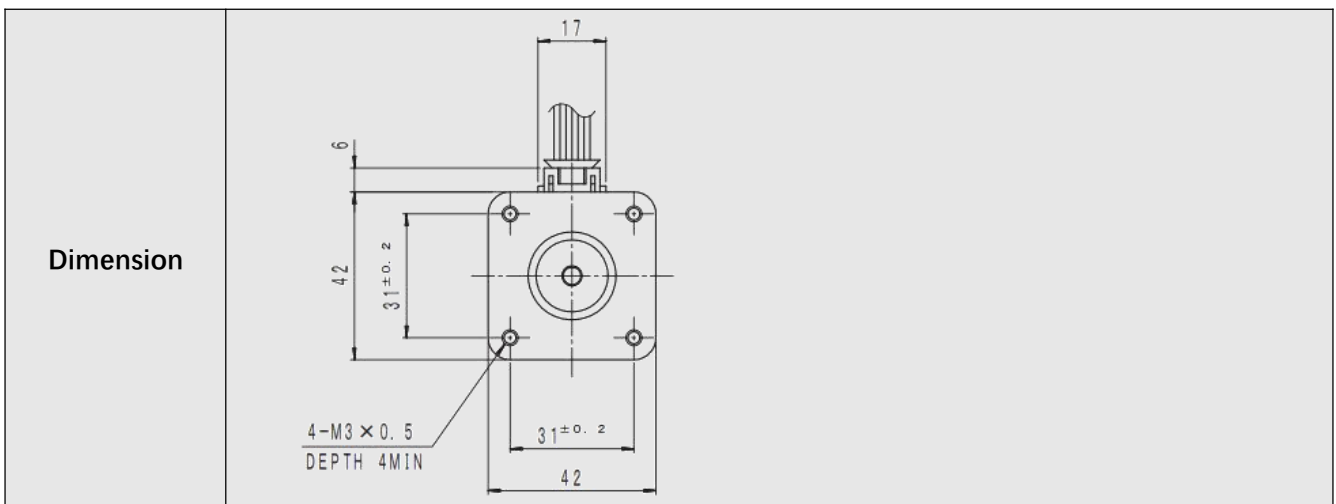

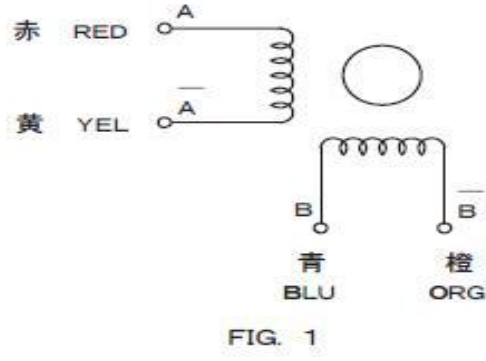
<b>Wiring</b>	 <p style="text-align: center;">FIG. 1</p>	
<b>Electrical parameters</b>	Maximum power Step angle Rated voltage Rated current Holding torque Resistance Inductance Braking Torque Rotational inertia Temperature limit Insulation level	9.2W 0.9° 4.6V 1.0A 390mNm 4.6Ω±0.46Ω 18.6mH REF 11.8mNm 62g·cm <sup>2</sup> 85C° MAX B
<b>Current setting</b>	The output current is set equal to or slightly less than the rated motor current value	

## 1.6 Typical Application (Solenoid Valve Connected to Syringe Pump)

### 1. Connecting Method

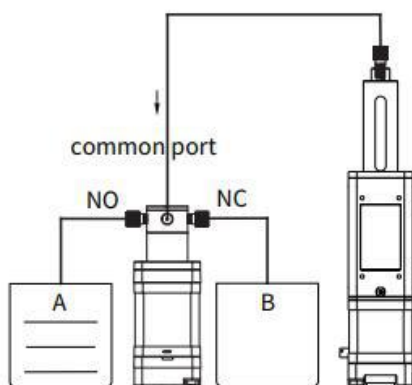

### 2. Working Flow

① To make syringe pump aspirates liquid, power on Mrv-01B valve, NO (normally open) and common port of Mrv-01B valve connected, pump transfer liquid from box A into syringe pump;



② To make syringe pump dispense liquid, power on Mrv-01B valve, NO (normally open) closed, NC (normally close) opened and connected with common port, pump transfer liquid from syringe into box B.

## 1.7 Basic Parameters

### A. Syringe Specification

5ml	1/4-28 female thread/ channel	
10ml	1/4-28 female thread/single channel	1/4-28 female thread/double channels
20ml	1/4-28 female thread/single channel	1/4-28 female thread/ double channels

### B. Product Function

Function	Direction
Address setup	Serial port
Baud rate setup	Different baud rates under RS232/RS485/CAN available
CAN target address setup	Superior device setup support
Speed setup	Serial setup 1-300rpm/min (air and liquid different)
Subdivision setup	Serial setup: subdivision must be 256 when speed as 1rpm
Reset internal data	Factory setting
Inquiry parameter	Device address, speed, subdivision, baud rate
Inquiry version	Current version
Motor direction	CW, CCW
Reset	Return piston to original position
Strong stop	Strong stop the running motor
Motor status inquiry	Inspect current motor status
Power memory	When motor suddenly stops, current position can be inquired by display the distance from original position
Collision protection	Upper and lower Optocoupler limits

### C. Technical Parameters

Item	Description		
Accuracy	≤1%@100% stroke		
Repeatability	3‰ - 7‰		
Pressure	0-1.0Mpa (air)      0-1.2Mpa (water)		
Service life	3 million times no leakage (media: water)		
Detection	Photosensor check original piston position for accurate location		
Specification	<b>5ml</b>	<b>10ml</b>	<b>20ml</b>
Rated stroke (control steps)	30mm (12000steps)	24.08mm (9632steps)	24 mm (9600steps)
Linear speed	0.017 – 5mm/s	0.017 – 5mm/s	0.017 – 4.167mm/s
Time range (rated stroke)	6s – 1800s	4.8s – 1445s	5.76s – 1440s
Accuracy resolution	0.0025mm/0.4167μL	0.0025mm/1.0382μL	0.0025mm/2.0833μL
Syringe inner diameter	14.55mm	23.03mm	32.57mm
Actuator	Ball screw (lead 1mm)		
Max piston drive	≥ 100N		
Sub piston drive	≥ 45N		
Wetted Material	Borosilicate cylinder, PTFE piston		
Max pressure	Positive air pressure 0-1.0Mpa; Negative air pressure 0-0.05Mpa		
Connector	1/4-28UNF Female		
Communication	RS232/RS485/CAN		
Baud rate	RS232/RS485; 9600dps/19200dps/38400dps/57600dps/115200dps CAN : 100kbps、200kbps、500kbps、1Mbps		
Address & Parameter setting	Serial port		
Dimension	47.5*42*206mm (L*W*H)		
Power supply	DC24V/1.5A		
Working temperature	5-55C°		
Working humidity	< 80%		
Dimension(L*W*H)	42*42*191mm (without drive)		
Weight	0.72kg		

## 1.8 Port Definition

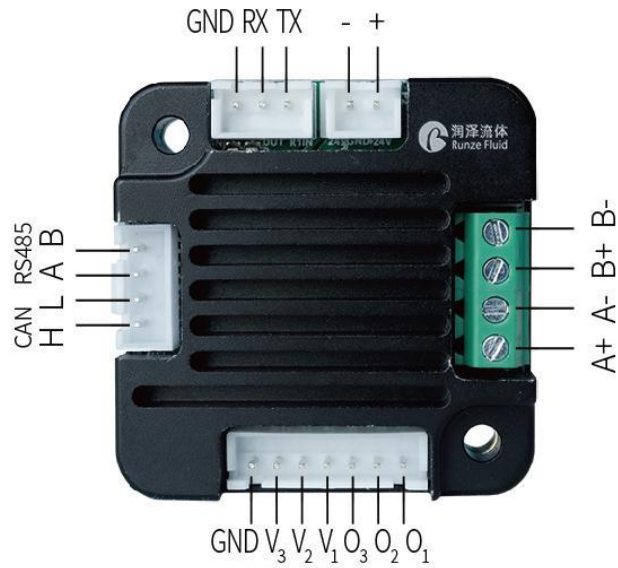

Drive Control Panel Diagram

D. Table 1-3 Driver board port descriptions:

Port name	Function	Port name	Function
+	DC24V positive	A-	Stepper motor A-
-	DC24V negative	B+	Stepper motor B+
TX	RS232 TX	B-	Stepper motor B-
RX	RS232 RX	O <sub>1</sub>	IO1
GND	RS232 Land	O <sub>2</sub>	IO2
H	CAN - H	O <sub>3</sub>	IO3
L	CAN - L	V <sub>1</sub>	V1
A	RS485 - A	V <sub>2</sub>	V2
B	RS485 - B	V <sub>3</sub>	V3
A+	Stepper motor A+	GND	Grounding wire

## Chapter 2 Syringe Pump Control Code Instruction

### 2.1 Overview

The data transmission between the syringe pump and the host computer (computer, single chip microcomputer, PLC, etc.) adopts serial communication (RS232, RS485, CAN bus). The following describes the communication format: the communication adopts asynchronous serial communication, the command and data frame adopt sum check, and the sum check is two bytes (2Byte). Commands and data in communication are in hexadecimal format, shown as 0x00~0xFF or 0x0000~0xFFFF, and the parameters are stored in little-endian mode.

**Communication Interface:** RS-232, RS-485, CAN bus;

**Communication Mode:** Bidirectional asynchronous, master-slave mode;

**RS232/RS485 Baud Rate:** 9600bps, 19200bps, 38400bps, 57600bps, 115200bps;

**CAN Baud Rate:** 100Kbps, 200Kbps, 500Kbps, 1Mbps;

**Data Bits:** 8 bits;

**Parity:** No parity check.

**Response time** <1 second

### 2.2 Installation and Debugging

1. Install the debugging tools, see 《Instructions for Debugging Tools》 for details
2. Instructions for use, see 《MINI SY-04Quick Use Guide》 for details.

### 2.3 Command Format Instruction

#### 2.3.1 Control Command Format

A: Pump Parameter Query Command (Common Command)

B: Pump Action Command (Common Command)

C: Pump Parameter Setting Command (Factory Command)

#### 2.3.2 Common Command Format (send 8 bytes, receive 8 bytes)

**Send Command:**

B0	B1	B2	B3	B4	B5	B6	B7
FH (frame header)	Address code	Function code	Status parameters		EOF (end of frame)	CUCUM (cumulative sum)	
STX	ADDR	FUNC	Bit 1-8	Bit 9-16	ETX	Low byte	High byte

- The 1st byte STX : Frame header (CCH)
- The 2nd byte ADDR : Slave address (00H ~ FFH)
- The 3rd byte FUNC : Function code
- The 4th , 5th byte : Parameters corresponding to the function code
- The 6th byte ETX : End of frame (DDH)
- The 7th , 8th byte : Cumulative sum check code from byte 1 to 6

#### Respond Command:

B0	B1	B2	B3	B4	B5	B6	B7
FH (frame header)	Address code	Status code	Status parameters		EOF (end of frame)	CUCUM (cumulative sum)	
STX	ADDR	STATUS	Bit 1-8	Bit 9-16	ETX	Low byte	High byte

- The 1st byte STX : Frame header (CCH)
- The 2nd byte ADDR : Slave address (00H ~ FFH)
- The 3rd byte STATUS : Status code
- The 4th , 5th byte : Parameters corresponding to the status code
- The 6th byte ETX : End of frame (DDH)
- The 7th , 8th byte : Cumulative sum check code from byte 1 to 6

#### a: Pump Parameter Query Command (Common Command)

Code B2	Instruction	Parameter B3. B4	Response Parameter Description B2 B3 B4
0x20	Query address	0x0000	0x0000 ~ 0x00FF(0 ~ 255)
0x21	Query RS232 baud rate	0x0000	There are five baud rates: the factory default is 9600bps The baud rate corresponds to B3B4=0x0000 is 9600bps The baud rate corresponds to B3B4=0x0001 is 19200bps The baud rate corresponds to B3B4=0x0002 is 38400bps The baud rate corresponds to B3B4=0x0003 is 57600bps The baud rate corresponds to B3B4=0x0004 is 115200bps
0x22	Query RS485 baud rate		

0x23	Query CAN baud rate	0x0000	CAN baud rate corresponds to: B3B4=0x0000 100Kbps B3B4=0x0001 200Kbps B3B4=0x0002 500Kbps B3B4=0x0003 1Mbps
0x25	Query Subdivision	0x0000	Range from : 0000-0008 B3B4=0x0000 [Full subdivision]    B3B4=0x0001 [2 subdivision] B3B4=0x0002 [4 subdivision]        B3B4=0x0003 [8 subdivision] B3B4=0x0004 [16 subdivision]       B3B4=0x0005 [32 subdivision] B3B4=0x0006 [64 subdivision]       B3B4=0x0007 [128 subdivision] B3B4=0x0008 [256 subdivision]
0x27	Query pump Max. speed	0x0000	0x0000 ~ 0x012C(0 ~ 300rpm)
0x30	Query CAN destination address	0x0000	B3=0xXX (B4=0x00) The value of XX range from 00 ~ FF, default 00
0x3F	Query current version	0x0000	B3B4 Software version number, in hexadecimal format
0xEF	Query current subversion	0x0000	B3B4 Software subversion number, in hexadecimal format
0x4A	Query motor status	0x0000	B2=0x00 Indicates that the device is idle and can send commands
0x66	Query current position	0x0000	B3B4 =0x0000 When the syringe pump suddenly stops working during operation, due to external reasons or a sudden power failure, the current position of the motor can be queried by command to display the number of steps between the current position and zero position of the piston. For example, if the command 0x66 is used to query, B3=0x3E B4=0x0A in the received command, which is 2622 in decimal. Then the distance between the current position and the zero position is 2622 steps, so as to calculate the volume of liquid suction or liquid discharge
0x67	Clear position	0x0000	B3=0x00 B4=0x00 When the syringe pump is suddenly powered off during operation, the pump will continue to run for a short period of time at the moment of power off, so the actual running steps are more than the original ideal steps. When the pump is powered on again (or issue the command 0X45 to reset), it will automatically reset, and the reset position of the motor will not be the zero position. At this time, the command 0x67 should be issued to return the position to zero. Then use 0x66 command to query the current position. B3=0x00 B4=0x00 in the received command indicates that the current position is the zero position.



0x68	Query the piston direction	0x0000	B3= 0x00 B4 =0x00 Query motor running status, B3= 0x00 B4 =0x00 in the received command indicates that the motor rotates counterclockwise, the piston moves downward, and the pump aspirates liquid; B3=0x01 B4=0x00 indicates that the motor rotates clockwise, the piston moves upward, and the syringe pump dispense liquid.
------	----------------------------	--------	---

### b: Pump Action Command (Common Command)

Code B2	Instruction	Parameter B3, B4	Response Parameter Description B2 B3 B4
0x42	Run the steps clockwise	Running steps	B3B4 > 0 When the number of steps corresponding to parameter B3B4 is greater than the number of steps from the motor to the reset optocoupler, the motor stops at the reset optocoupler; When the number of steps corresponding to parameter B3B4 is less than the number of steps from the motor to the reset optocoupler, the motor rotates according to the set number of steps
0x4D	Run the steps counterclockwise	Running steps	The maximum value range of B3B4 is determined by the capacity of the glass syringe of the pump: According to table 1-2, the single-step sample volume of the syringe pump with the specification of 5ml is 0.4167ul, and the maximum step number is $5\text{ml} \div 0.4167\text{ul} \approx 12000$ . which converted into a hexadecimal number is 0x2EE0, the value of B3B4 ranges from 0x0001 to 0x2EE0. For other specifications, the maximum number of steps can be calculated based on the number of single steps.
0x45	Reset of syringe pump	0x0000	B3=0x00 B4=0x00 The syringe pump runs to the optocoupler position and stops
0x4B	Set dynamic speed (Set this value before pump operation, the value will be invalid after power failure, if not set, the default speed set by factory instruction)	0x0000	The value of B3B4 ranges from 0x0001 ~ 0x012c. The motor rotation speed ranges from 1 ~ 300rpm. The maximum speed of 5ml and 10ml ranges from 1 ~ 300rpm, and the maximum speed of 20ml ranges from 1 ~ 250rpm. Note: When the speed is set to 1, the subdivision must be 256 subdivisions
0x49	Forced stop	0x0000	B3B4 remaining steps

### 2.3.3 Factory Command Format (send 14 bytes, receive 8 bytes)

Factory command should be used with the V0.6 debugging tool when RS232 /RS485 are used alone. For details, see the 《Quick Use Guide》

**Send Command:**

FH (frame header)	Address code	Function code	Code	Function parameters				EOF (end of frame)	Sum check	
				B7	B8	B9	B10		B11	B12
B0	B1	B2	B3,B4, B5,B6	Bit 1-8	Bit 9-16	Bit 17-24	Bit 25-32	ETX	Low byte	High byte
STX	ADDR	FUNC	0xAABBEFF							

- The 1<sup>st</sup> byte STX : Frame header (CCH)
- The 2<sup>nd</sup> byte ADDR : Slave address (00H ~ FFH)
- The 3<sup>rd</sup> byte FUNC : Function code
- The 4<sup>th</sup>-7<sup>th</sup> byte : Factory command code
- The 8<sup>th</sup>-11<sup>th</sup>byte : Parameters corresponding to the function code
- The 12<sup>rd</sup> byte ETX : End of frame (DDH)
- The 13<sup>th</sup>, 14<sup>th</sup> byte : Cumulative sum check code from byte 1 to 12

**Respond Command:**

FH (frame header)r	Address code	Status code	Status Parameter		EOF (end of frame)	Sum check	
			B3	B4		B6	B7
B0	B1	B2	Bit 1-8	Bit 9-16	ETX	Low byte	High byte
STX	ADDR	STATUS					

- The 1<sup>st</sup> byte STX : Frame header (CCH)
- The 2<sup>nd</sup> byte ADDR : Slave address (00H ~ FFH)
- The 3<sup>rd</sup> byte STATUS : Status code
- The 4<sup>th</sup>, 5<sup>th</sup> byte : Parameters corresponding to the status code
- The 6<sup>th</sup> byte ETX : End of frame (DDH)
- The 7<sup>th</sup>, 8<sup>th</sup> byte : Cumulative sum check code from byte 1 to 6

**C: Pump Parameter Setting Command (Factory Command)**

Code B2	Instruction	Command code B4B3 range	Parameter Description
0x00	Set device address	0x0000 ~ 0x00FF	Address : 0 ~ 255
0x01	Set RS232 baud rate	0x0000 ~ 0x0004	Totally five baud rates: the factory default is 9600bps The baud rate corresponds to B3B4=0x0000 is 9600bps The baud rate corresponds to B3B4=0x0001 is 19200bps The baud rate corresponds to B3B4=0x0002 is 38400bps The baud rate corresponds to B3B4=0x0003 is 57600bps The baud rate corresponds to B3B4=0x0004 is 115200bps
0x02	Set RS485 baud rate	0x0000 ~ 0x0004	

0x03	Set CAN baud rate	0x0000 ~ 0x0003	<p>There are four baud rates: the factory default is 100K</p> <p>The baud rate corresponds to B3B4=0x0000 is 100Kbps</p> <p>The baud rate corresponds to B3B4=0x0001 is 200Kbps</p> <p>The baud rate corresponds to B3B4=0x0002 is 500Kbps</p> <p>The baud rate corresponds to B3B4=0x0003 is 1Mbps</p>
0x05	Set subdivision	0x00000x0008	<p>Value range: 0000-0008</p> <p>B3B4=0x0000 Full subdivision</p> <p>B3B4=0x0001 2 subdivision</p> <p>B3B4=0x0002 4 subdivision</p> <p>B3B4=0x0003 8 subdivision</p> <p>B3B4=0x0004 16 subdivision</p> <p>B3B4=0x0005 32 subdivision</p> <p>B3B4=0x0006 64 subdivision</p> <p>B3B4=0x0007 128 subdivision</p> <p>B3B4=0x0008 256 subdivision</p>
0x07	Set Max. speed	0x0001 ~ 0x12C	The maximum speed of the current device can be set to 300rpm, but it must be set based on the actual condition of the device
0x0E	Set reset automatically after power-on	0x0000 ~ 0x0001	<p>B3B4=0x0000 indicates not reset automatically after power-on</p> <p>B3B4=0x0001 indicates reset automatically after power-on</p>
0x10	Set the destination of CAN	0x0000 ~ 0x00FF	address : 0 ~ 255

### Status List

Category	Status (B2)	Response frame (B2) corresponding meaning of status
Response Status	0x00	Normal state
	0x01	Frame error
	0x02	Parameter error
	0x03	Optocoupler error
	0x04	Motor busy
	0x05	Motor stalling
	0x06	Unknown locations
	0x07	Command rejected
	0x08	Illegal location
	0xFE	Task execution
	0xFF	Unknown error

**Note:** In RS485 communication, when the action command is sent, B2 byte receives FE, indicating

that the command is received and being executed

(1) Code B2 in response command means current motor status. Only when B2=0x00 motor works normally. Other codes means different motor breakdown. Other parameters are shown in the table above corresponding to different abnormal states respectively. In principle, the command 0X4A should be issued after the motor runs to query the motor state. Only when the parameter B2 in the response command is 00, other commands can be correctly executed.

**Kind Reminder:**

1. All code parameters are set by little-endian. Little-endian storage means low data position stored in the low address, high data position stored in the high address.

2. When the syringe pump is powered off suddenly during operation, the pump will continue to run for a short period of time. At this time, the number of running steps will be deviated, and the reset position will not be the home position when the pump is powered on again. At this time, the command 0x67 should be issued to return the pump to home position, which is helpful to reduce the error and generally used after the reset command

3. Deviation steps is 0-15steps when 24V powered off, while 0-55steps when 240V powered off. (Deviation steps was worked out by average test value)

## Chapter 3 Common Problems and Solutions

Item	Fault	Reason	Troubleshooting method
1	Not working when powered on	The working voltage is not in the acceptable range	Check whether the actual voltage deviates from the rated voltage
		The connection is loose or disconnected	Manually check whether the connection is good, or check the line with a multimeter
2	Unable to aspirate or aspirate properly	The pipe system is not tightly sealed	Check whether the joint is tight
		The aspirating pipe is blocked	Clean and dredge the pipe
		The aspirating valve or the dispensing valve is blocked by debris	Clear the debris
3	Bubbles	Air leakage in aspirating pipe	Find the leak and eliminate it
		The inlet and outlet pipe joints are not tightly sealed	Replace the gasket and tighten the pipe joint
		Gasket broken	Replace the gasket
		Excessive fluid pipe diameter variation	The diameter of the fluid path should be as consistent as possible
4	Motor overheated	Drive voltage is too large	Adjust voltage
		Drive current is too large	Adjust current
		Holding current is too large	Holding current $\leq 50\%$ of rated current

### Application Notice:

- Please ensure that the voltage matches the standard voltage of the instrument.
- Please use original serial port wires
- Communication RS232, RS485, CAN are under Non-isolation mode, hot swapping unsupported.
  - Please cover the unused ports with suitable coned plugs when laid aside to avoid impurity substance and air
  - Do not disassemble the product parts at will. The tamper-evident label is not guaranteed.
  - Please read above operation instructions and communication protocols carefully, do not input data randomly.
  - Discard the instrument should be in line with the regulations on the disposal. Dispose of the waste in accordance with national environmental protection requirements. Users should not throw away at will.

- When using CAN protocol to connect multiple devices, please refer to the connection method shown in Figure 3-1 below.

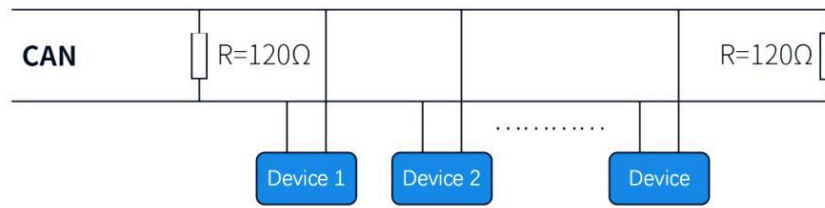

Figure 3-1

- When using RS485 protocol to connect multiple devices, please refer to the connection method in Figure 3-2 below, but the resistance value needs to be determined according to the number of devices connected by the user.

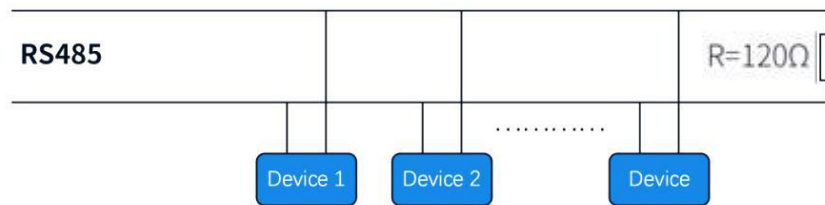

Figure 3-2



## Chapter 4 Technical Service



Tel : +86-25-51197362 Fax : +86-25-51197362

Phone : +86-138 5195 4068

Technical support : +86-183 5195 5944、 +86-198 2581 4316

Official URL : <http://www.runzefluid.com>

Alibaba Store URL : <https://runzeliuti.en.alibaba.com>

Sales Email : [xiaoyan.xiang@runzeliuti.com](mailto:xiaoyan.xiang@runzeliuti.com)

Address : NO.9 Tianxing West Road, Dongshan Street, Jiangning District,  
Nanjing, Jiangsu, China



Official URL



Alibaba Store URL



Aliexpress Store URL